

S1PDB174N18

Single Phase Bridge Rectifiers Modules

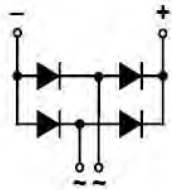

Type	V _{RSM} V	V _{RRM} V
S1PDB174N08	900	800
S1PDB174N10	1100	1000
S1PDB174N12	1300	1200
S1PDB174N14	1500	1400
S1PDB174N16	1700	1600
S1PDB174N18	1900	1800

Dimensions in mm (1mm=0.0394")

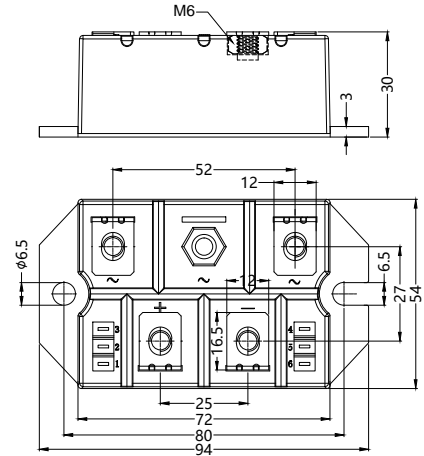

Symbol	Test Conditions	Maximum Ratings	Unit	
I _{dav}	T _C =100°C, module	174	A	
I _{dav}	T _A =35°C (R _{thCA} =0.2K/W), module	139		
I _{FSM}	T _{VJ} =45°C V _R =0 t=10ms (50Hz), sine	2800	A	
	T _{VJ} =T _{VJM} V _R =0 t=8.3ms (60Hz), sine	3300		
I ² t	T _{VJ} =45°C V _R =0 t=10ms (50Hz), sine	2500	A ² s	
	T _{VJ} =T _{VJM} V _R =0 t=8.3ms (60Hz), sine	2750		
T _{vj}	T _{vjm}	39200		°C
		45000		
T _{stg}	T _{vjm}	31200	°C	
		31300		
V _{isol}	50/60Hz, RMS I _{isol} ≤ 1mA t=1min t=1s	-40...+150	V~	
		150		
M _d	Mounting torque (M6) Terminal connection torque (M6)	-40...+125	Nm	
		2500		
Weight	typical	3000	g	
		5 ± 15%		
		5 ± 15%		
		270		

Sirectifier®

S1PDB174NXX

Single Phase Bridge Rectifiers Modules

Symbol	Test Conditions	Characteristic Values	Unit
I_R	$V_R=V_{RRM}; T_{VJ}=25^{\circ}C$ $V_R=V_{RRM}; T_{VJ}=T_{VJM}$	≤ 0.3 ≤ 5	mA
V_F	$I_F=300A; T_{VJ}=25^{\circ}C$	≤ 1.43	V
V_{TO}	For power-loss calculations only	0.8	V
r_T	$T_{VJ}=T_{VJM}$	2.2	m Ω
R_{thJC}	per diode; 180° per module	0.45 0.11	K/W
R_{thJK}	per diode; 180° per module	0.6 0.15	K/W
d_s	Creeping distance on surface	10	mm
d_A	Creepage distance in air	9.4	mm
a	Max. allowable acceleration	50	m/s ²

FEATURES

- * Package with screw terminals
- * Isolation voltage 3000 V~
- * Glass passivated chips
- * Blocking voltage up to 1800 V
- * Low forward voltage drop
- * UL File NO.E310749
- * RoHS compliance

APPLICATIONS

- * Supplies for DC power equipment
- * Input rectifiers for PWM inverter
- * Battery DC power supplies
- * Field supply for DC motors

ADVANTAGES

- * Easy to mount with two screws
- * Space and weight savings
- * Improved temperature and power cycling